

# VULCAN®

## LONG LASTING, ROBUST AND ECONOMICAL



### THAT'S VULCAN® VALUE

High quality and performance at a very affordable price. Three good reasons why Vulcan is such a popular choice for reliable water heating.

**Vulcan is built with the best:** Quality materials and leading edge technology combine to make Vulcan ready for year after year of reliable hot water service. Colorbond®<sup>1</sup> steel jackets, which are both weatherproof and corrosion resistant, protect against our harsh climate.

**Vulcan is tough:** The Vulcan storage cylinder is made from specially formulated steel tough enough to withstand varying water and heating cycle pressures.

**Vulcan is adaptable:** The balanced flue and attractive Colorbond®<sup>1</sup> steel jackets are designed to make Vulcan gas models easy to install and easy to live with. They can be installed on an approved base against a wall or recessed into a wall cavity if space is limited.

**Vulcan's inside story is just as strong:** A ceramic lining is bonded to the inside of the cylinder providing long life protection against the varying water conditions found across Australia.

**Vulcan has backup:** If you ever need a spare part for your Vulcan it's good to know they are readily available across the country and can be serviced by most plumbers or electricians. The Vulcan Warranty<sup>†</sup> covers the cylinder for a full 5 years. (A new water heater will be supplied in accordance with the terms of the warranty if the cylinder fails within 5 years). Every Vulcan water heater also comes with a 12 month warranty on parts and labour.



FORGED TOUGH

## HOW TO CHOOSE THE RIGHT VULCAN®

Your Vulcan will be living with you for a long time, so make sure you select the one to suit your needs. Take into consideration appliances such as washing machines and dishwashers, which can use as much hot water as one person. Also allow for family additions and don't forget – small children grow into large teenagers.

Use the charts below as a guide for calculating your average usage, and for selecting the right Vulcan model for you.

Warranty		Model	
<b>Vulcan Gas</b>			
Vulcan Quick Recovery	5 Years†	641135	641170
Trim Kit		FK135	FK170
AGA Energy Gas Rating		3	3
Storage Capacity	Litres	135	170
Dimensions	A	mm	1558
	B	mm	422
	C	mm	502
	D	mm	988
	E	mm	328
	F	mm	298
	G	mm	1478
	H	mm	473
	L	mm	208
Approx. Weight Empty	kg	59	69
Relief Valve Setting	kPa	1400	1400
ECV Setting #	kPa	1200	1200
Max. Supply Pressure	kPa		
		960	960
		1120	1120
Hourly Gas Consumption			
	Natural	Mj	30
	Propane	Mj	30
Water Connections (LHS)		RP ¾/20	RP ¾/20
Gas Connection		RP ½/15	RP ½/15

Warranty		Model							
<b>Vulcan Electric</b>									
Vulcan Single Element Left Handed	5 Years†		661080	661125	661160	661250	661315	661400	
Vulcan Single Element Dual Hand	5 Years†	691050							
Vulcan Twin Element							662315	662400	
Hot Water Delivery	Litres	50	80	125	160	250	315	400	
Storage Capacity	Litres	53	90	135	165	270	325	410	
Boost Capacity	Litres						50	90	
Dimensions	A	mm	695	945	1340	1610	1395	1640	1840
	B	mm	393	480	480	480	640	640	690
	C	mm	429	515	515	515	675	675	730
	D	mm	397	702	1102	1332	1117	1317	1479
	E	mm	142	64	64	104	73	113	121
	F	mm	80	84	84	84	128	128	129
	G	mm	–	–	–	–	–	1255	1346
	H	degrees	26	23	23	23	32	32	30
	J	degrees	59	58	58	58	88	88	83
	Approx. Weight empty	kg	30	34	46	52	70	88	112
Relief Valve Setting	kPa	1400	1400	1400	1400	1000	1000	1000	
ECV Setting #	kPa	1200	1200	1200	1200	850	850	850	
Max. Supply Pressure	kPa								
		960	960	960	960	680	680	680	
		1120	1120	1120	1120	800	800	800	

Hot and cold water connections RP ¾/20. All water heaters operate on 240 volt single phase electricity supply. # ECV not supplied with water heater.

† Warranty: 5 years on cylinder. 3 year labour on cylinder. 1 year on parts and labour.

For full details contact your nearest Vulcan distributor.

### Storage Tank Dimensions

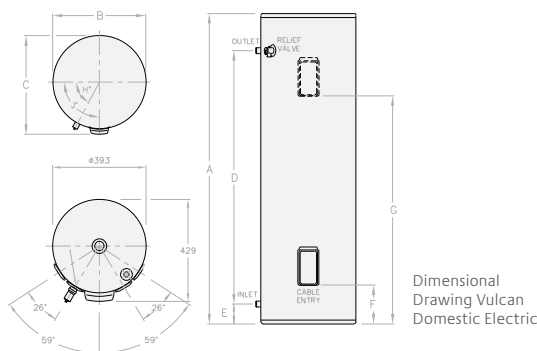
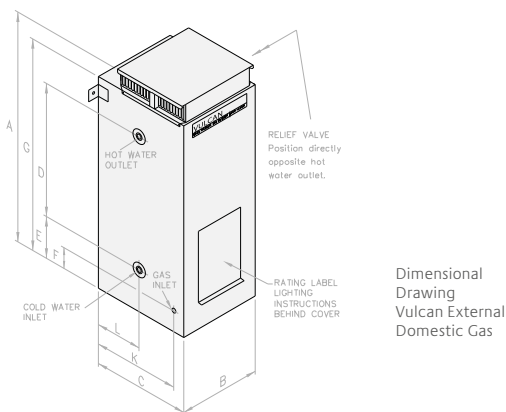

### SIZING GUIDE

#### Vulcan Gas

Storage Capacity in Litres	135	170				
No. of people – Moderate Climate	2-4	3-5				
No. of people – Cool Climate	2-3	3-4				

#### Vulcan Electric

Delivery in Litres	50	80	125	160	250	315	400
Continuous Tariff							
No. of People	1-2	2-3	2-4	3-5	4-6	5-9	
No. of Bedrooms				1-2	3	4-5	
Off-Peak Tariff							
No. of People				1-3	2-4	4-6	

### Rheem Australia Pty Ltd. Head Office

1 Alan Street, Rydalmere, New South Wales 2116, Australia  
PO Box 6, Rydalmere, New South Wales 2116, Australia

National Sales Phone: 132 552

National Sales Fax: 1300 554 821

National Service Phone: 131 031

® Registered trademark of Rheem Australia Pty Ltd.

™ Registered trademark of SAI Global.

®<sup>1</sup>Colorbond is a registered trademark of BlueScope Steel Limited.



**VULCAN®**

FORGED TOUGH