



airoheat[®]

heat pump specifications

NEW
sub-zero
model
heats water in sub-zero temperatures

thinkquiet
quieter than other comparable heat pumps

thinkefficient
more efficient than other comparable heat pumps

thinksubzero
innovative de-icing function for cold climates



thinkhotwater

1300 365 116
www.dux.com.au

airoheat[®] heat pump system

Airoheat[®] Subzero explained

The Dux Airoheat[®] is the most efficient heat pump water heater in its class due to the New Heat Technology or NHT. Lets consider the efficiency of Airoheat[®] in two parts.

The first part is the efficient creation of the heat using state of the art components.

The second part is how & where the heat is transferred into the water. What makes Airoheat[®] so efficient is that the heat transfer occurs within the water inside the tank. As a result it gets direct heat transfer and isn't exposed to some of the heat loss issues associated with other styles of heat pump water heaters.

Airoheat[®] Subzero new features

- Airoheat[®] Subzero now includes an innovative de-icing function so there's no need for a back-up element.
- Management by the innovative Hotlogic[®] controller, allows the Airoheat[®] to keep running when the air temperature drops below zero.
- It is also lighter to make it easier to handle.
- More efficient than the original Airoheat[®], the Subzero receives an additional 2 RECs points.

Airoheat[®] is still

- Easy to install
- An easy change over from an electric storage water heater
- Significantly lower on electrical consumption
- Quiet
- A Renewable Energy Certificate (REC) approved product
- Full mains pressure delivery



SPECIFICATIONS	AIROHEAT
Capacity	250L
Net weight empty	113 kg
Power consumption (general tariff)	1.2 kW
Max water supply pressure	800 kPa
Free air flow	1500 m ³ /h
Sound level	50 dB
Rated voltage	240V ac
Evaporator area	0.36 m ²

Not suitable for installation in alpine areas or areas above 1000m.



RECs Table – Heat Pump

PRODUCT CODE: D2FH00000C		RECS ZONE			
		1	2	3	4
250 Litres	Airoheat Subzero	30	26	30	30

REC values are subject to change without notice & are correct at time of printing. RECs calculations are based on continuous tariff.

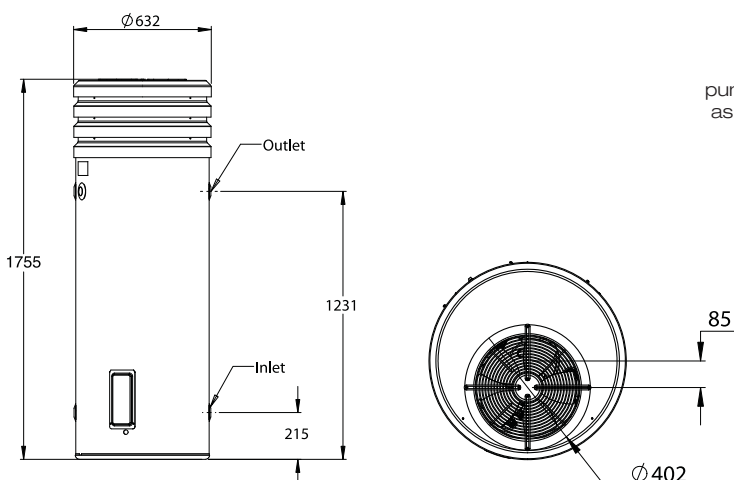

Some other comparable heat pumps produce twice as much noise as the Dux Airoheat[®].

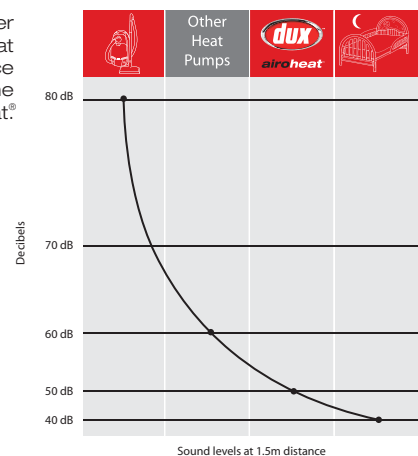

Contact Dux for your Hot Water Solutions

Sales: 1300 365 116 Service: 1300 365 115 Web Site: www.dux.com.au
 © Dux Manufacturing Limited ABN 19 077 879 844. Lackey Rd, PO Box 209 Moss Vale, NSW 2577
 The information supplied was correct at time of printing. Specification and materials may change without notice.
 © and ™ indicate trademarks of Dux Manufacturing Limited. Dux Manufacturing Limited is proudly Australian owned.

